

LASER MICROGAGE 2000 System

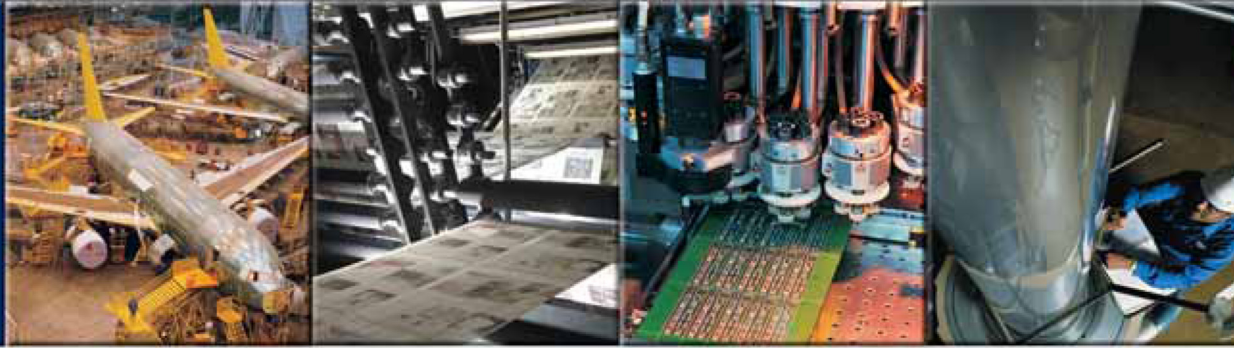

Laser Microgage

The Laser Microgage brings measuring and alignment versatility to industry in a simple, easy to use, and affordable package. The Laser Microgage 2000 is an enhanced, digital alignment system built for the industrial user that needs to align machinery and equipment quickly and efficiently right on the factory floor. The Microgage is ideal for aligning, measuring, calibrating and installing equipment, yet versatile enough to be used on many other projects. Providing precise measurements to .0001 inch or better and working ranges of 80 feet or more, the Microgage 2000 delivers powerful capability to industrial users. Simple to set up, the Microgage can be quickly adapted to assist you in difficult applications throughout your facility.



Practical and flexible for the changing demands of today's industry, the Microgage is expanding the capabilities for precision measuring and alignment while saving you time and money. We encourage you to contact our staff with your questions and application ideas.

PINPOINT Laser Systems

PINPOINT Laser Systems is a recognized manufacturer of precision alignment and measuring products for industrial applications. Established in 1992, the company designs and manufactures an expanding line of measuring and alignment products that utilize lasers and innovative optical technologies to assist customers in a wide variety of industrial applications. These products are actively used for engineering, preventative maintenance, production, field service, equipment installations, quality control and related uses.

Headquartered in Peabody, Massachusetts, Pinpoint maintains a complete manufacturing plant with facilities for production, product design, prototyping, OEM subsystem development, and custom manufacturing. Pinpoint products have been patented and featured in numerous publications, receiving awards for their innovative design, quality and use. Products are available from Pinpoint as well as through regional distributors and representatives and shipped throughout the United States, and exported around the world.



Benefits

- Improves efficiency and in-house capabilities
- Minimizes machinery downtime
- Easy to use, removes guesswork from alignment
- Supports preventative maintenance efforts
- Reduces dependence on outside alignment contractors
- Cuts machinery installation costs
- Highly affordable
- Rapid payback on investment

Product Features

- Easy to use and highly intuitive
- Delivers precise measuring capability
- Operates over a large working area
- Clear LCD display
- Battery operated
- Rugged, compact laser and receiver design
- Interchangeable laser and receiver options expand uses
- Machined mounting surfaces with hard anodized coating
- Highly portable, supplied with case
- Expandable kits cover many applications
- Computer interface and software option is easy to learn



3M Corporation
AGFA Electronics
Alcan Ingot
Alcan Rolled Products
Alcoa Packaging
American National Can Corp
Ampex Recording Media
Amtrak High Speed Rail
Applied Bio Systems
Argonne National Laboratory
Armco Steel, Inc.
B & D Manufacturing
Baxter Health Care Corp.
Bell and Howell Corp.
Boehinger Mannheim Co.
Boeing
Bowaters Inc.
Commonwealth Aluminum Corp
Continental Airlines
CSX Corporation
Dept. Of the Navy
Detroit Edison
Digital Measurement Metrology, Inc.
Dupont

Basic Microgage Capabilities

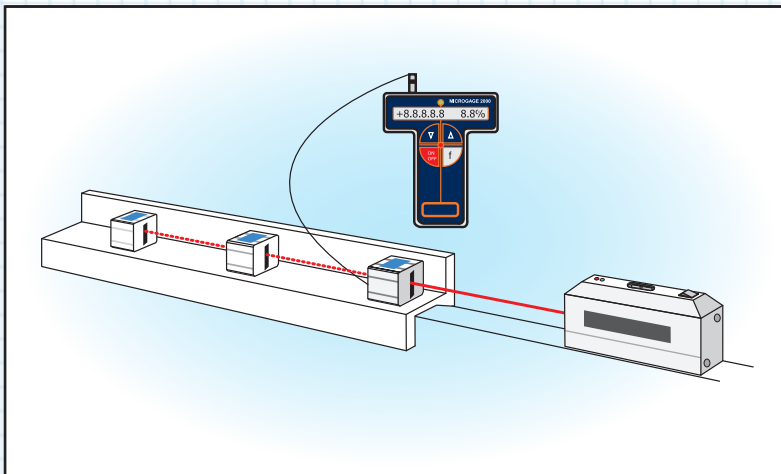

Straightness - Linear Measurements

The Laser Microgage is ideally suited for measuring linear runs to determine if a machine, rail, slide or assembly is running straight and true. Simply placing the digital receiver into the laser beam provides a precise measure of receiver's position and small deviations can be observed.

Examples include: Measuring stage and slide run out, checking rail and track straightness, and bore alignment.

Flatness - Planer Measurements

Placing the laser transmitter onto a precision rotating base defines a flat plane of laser light for measuring surface flatness and aligning components and assemblies in a precise plane. The digital receiver is moved to various locations and provides an accurate measure of surface height and profile.

Common applications include profiling machine beds, adjusting web and roller systems, checking gantry travel and positioning machinery.

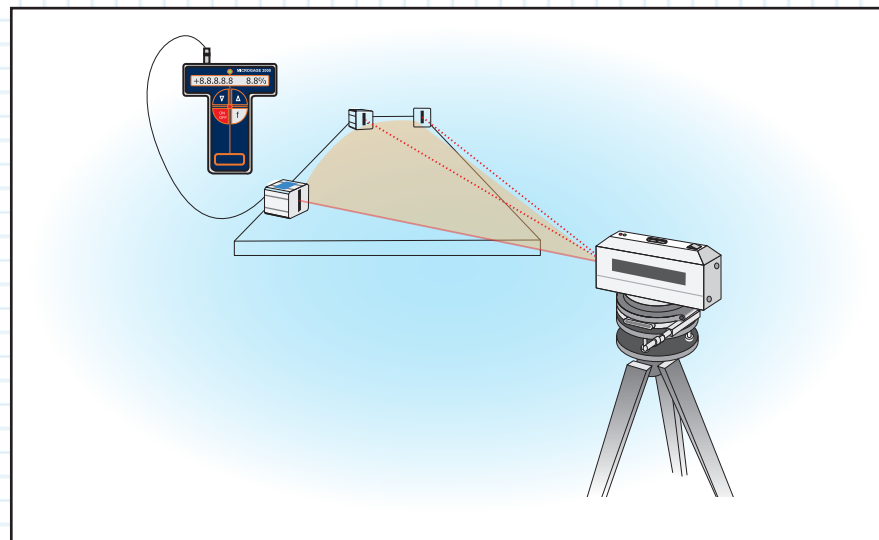

Squareness - Perpendicular Measurements

Placing Pinpoint's 90-Line into the laser beam path redirects the laser beam along a precise right angle. Again, placing the digital receiver into the laser path enables the user to measure squareness and expands the possibilities for geometric measuring.

Practical uses include checking Z-axis travel, squaring guides and actuators, positioning linear stages, and inspecting milling and cutting systems.

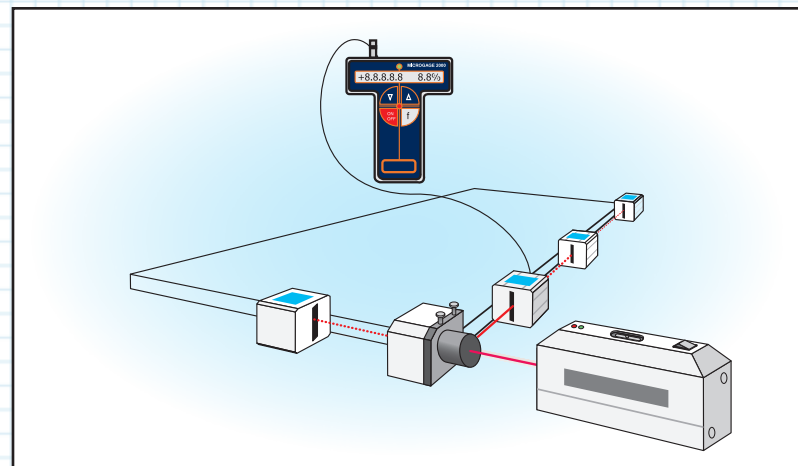

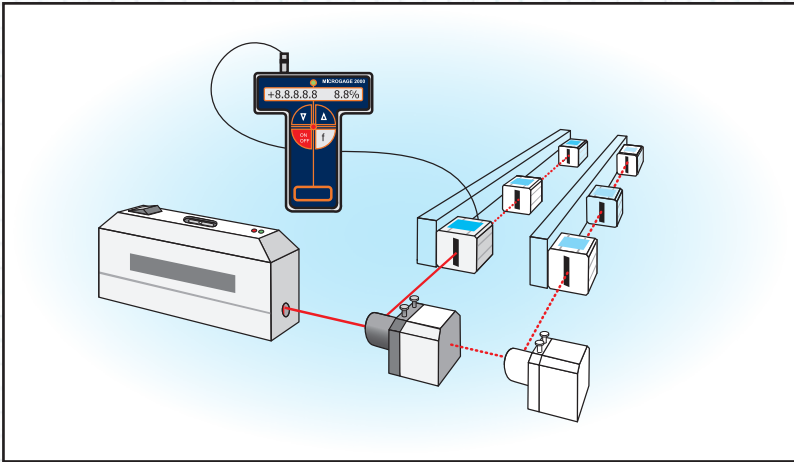

Parallelism Measurements

Pairs of parallel laser lines are easily created by moving the 90-Line to different positions along the laser beam. Once again, the digital receiver is placed into any line of laser light and provides a precise measurement of a component or assembly's relative position.

Common applications include aligning gantry rails, positioning moving slides to other assemblies, checking parallel edges, aligning rollers and web handling systems.

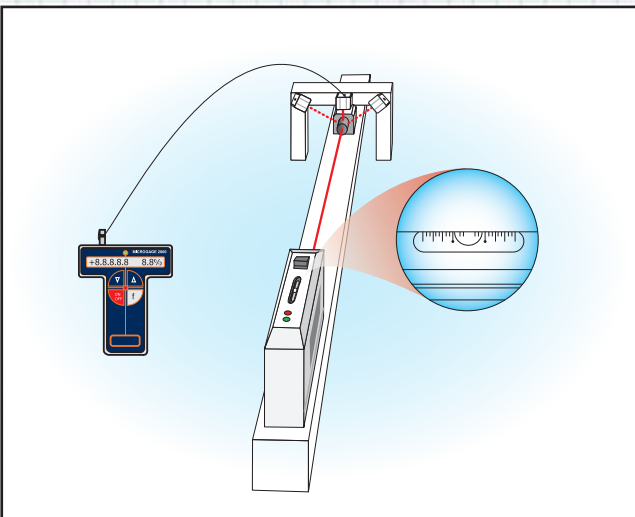

Leveling - Orientation to Gravity

Any of the measurements made for straightness, flatness, squareness or parallelism can be leveled to gravity by orienting the laser transmitter with the laser's precise machinist's level. This accurate leveling vial insures that the laser beam path is level and provides convenient reference for alignment and positioning.

Typical applications include leveling machine tools, positioning electronic solder wave systems, adjusting bearings on fast rotating turbofan equipment and aligning test instrumentation.

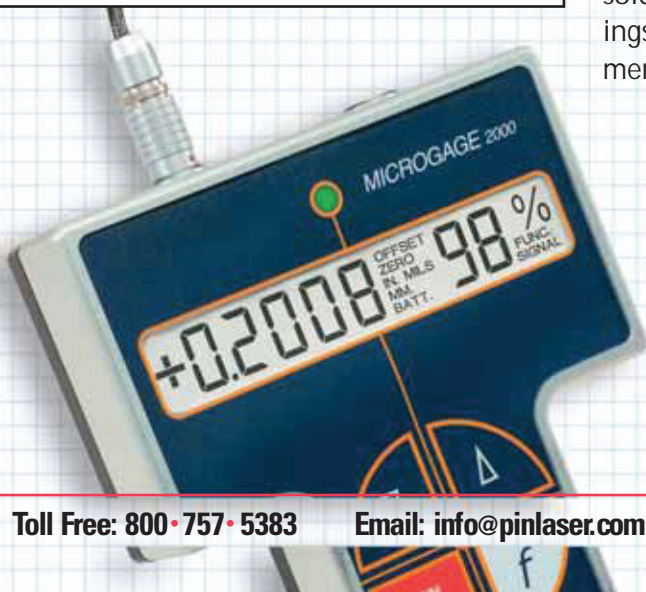

- Eastman Chemical Corp
- Flexcon Company
- Fort Howard Paper
- General Atomic
- General Dynamics
- General Tire
- Genus Semiconductor Corp
- Goodyear
- Heidelberg Web Systems
- Hewlett Packard
- Honeywell
- I.M.C. Canada Ltd.
- Interhold Corp
- Kaiser Cement Corp.
- Kal Kan Foods
- Kimberly Clark Corp.
- Libby Owens Ford
- Lockheed
- M & S Sheet Metal
- Marathon Electric
- Mead Paper Corp.
- Millipore
- Monadnock Mills
- Mueller Tool & Machine
- N.O.A.A.
- Narragansett Coated Paper Corp.
- National Glass Ltd.
- National Graphics
- Naval Air Warfare Center
- Navistar International
- Nike
- Osram Sylvania
- Otis Elevator Co.
- Pfautler, Inc.
- Pitt-Des Moines Steel
- PPG Industries
- Quality Calibration, Inc.
- Reynolds Metals Company
- S2 Yachts Inc.
- Saint-Gobain Fabrics
- Siemens Power Group

Applications

Some of the ways our customers use the Microgage

Unlike expensive equipment that is designed for a single specific task, the Laser Microgage is ready to go to work on all of your measuring and alignment projects such as:



- Measuring stage and table run out
- Fine adjusting of roller & guide assemblies
- Aligning bearings
- Locating gantry rails and cross bridges
- Assembling long machinery runs
- Checking rail and track parallelism
- Gaging large parts and assemblies
- Precise machine leveling and alignment
- Measuring surface flatness
- Aligning shafts and transmissions
- Aligning turbines
- Measuring structural and shaft deflections
- Aligning belts and drive systems
- Checking machinery clearance and wear
- Adjusting large web systems
- Adjusting frames and fixtures
- Checking milling and cutting stations
- Measuring straightness
- Bore alignment
- Squaring cutting machine axes
- Checking injection molding machines
- Aligning stamping presses

Specifications

Measurement resolution	0.0001 inch
Resolution with interface	0.00005 inch
Measurement range:	+/- 0.230 inch
Operating distance:	0 to 60 feet
Enhanced operating distance:	Up to 90+ feet
Measurement accuracy:	1% of measurement
Laser characteristics:	635nm, laser diode
Laser beam accuracy:	≤ 2 Arc Seconds
Laser beam repeatability:	≤ 1 Arc Second
Suggested warm-up time:	5 minutes
Laser leveling vial:	Bubble Type: < 15 Arc Seconds
Laser power:	Battery Pack, 4 AA Batteries
Laser run time:	20 hours, continuous
Laser mounting:	1/4-20 & 10-32 threaded holes
Laser surface finish:	Machined flat, anodized coating
Display:	LCD for reading, signals & icons
Display controls:	Function, Up, Down, Power
Display units:	Inch, millimeters, mils, custom
Display connections:	Receiver input, output interface
Display interface:	Serial RS232c, USB Option
Display power:	9 volt battery
Display run time:	16 hours continuous
Display housing:	Machined aluminum, anodized
Operating conditions:	30°F to 130°F (-1°C to +55°C)
Receiver options:	Interchangeable modules
Dimensions:	
Laser transmitter:	8.0" L x 2.0" W x 3.0" H
Receiver (standard):	2.0" L x 2.0" W x 2.0" H
Display unit:	8.0" L x 5.0" W x 1.5" H



Product Warranty and Service

Pinpoint has a comprehensive, 1 year warranty on the Laser Microgage and all available accessory items. Replacement parts and labor are fully covered. We also have extra units available that we can provide if yours is damaged and requires repair at our facility.

Custom and OEM Products

Pinpoint maintains a complete manufacturing plant with facilities for production, product design, prototypes, OEM subsystem development and custom manufacturing.

Key Accessories

Leveler Rotational Mount



90-Line Beam Bender



Computer Interface & Software

1 Leveler Rotational Mount

A precision mounting base for supporting the laser transmitter to measure and set flat reference planes. The laser is aligned by three fine adjustment knobs and can be rotated to any position for checking planes, leveling equipment and similar projects. The Leveler is also available with a fine micrometer rotational adjustment control and brake.

2 90-Line Beam Bender

This right angle beam bender redirects the laser beam on a precise right angle path for squaring machinery, checking parallelism, and other geometric alignment tasks. The 90-Line can be placed anywhere along the beam path and includes a four position indexing lock and brake for positioning the reference beam.

Computer Interface & Software

The computer interface connects your Microgage to a PC or laptop, greatly expanding the capabilities for precision measuring, recording readings and analyzing data. Also included is Pinpoint Capture, a simple software program for Windows that records readings, scales results, and offers other functions.

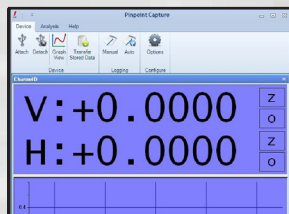

- SmithKline Beecham
- Southeast Valve, Inc.
- Stanley Tools
- Stone & Webster Engineering
- Sunoco
- Tetco Steel Corp.
- The Budd Company
- Torca Products
- TRW Transportation
- U.S. Naval Academy
- U.S. Postal Service
- US Dept of Energy
- US Geological Survey
- USX Corp.
- Varian Semiconductor Equipment
- Walt Disney
- Westinghouse Electric
- Weyerhaeuser
- Wright Patterson AFB
- XTH Industries





Pinpoint
Laser Systems

56 Pulaski Street • Peabody, MA 01960

Toll-free: 800-757-5383 • 978-532-8001

Fax: 978-532-8002 • Email: info@pinlaser.com

Website: www.pinlaser.com