



Laser Microgage PRO Dual Axis Measuring System: *Mud Pump Alignment Kit*

Industry Customers:

- Southwest Oilfield
- HongHua America
- American Block
- National Oilwell Varco
- Premium Oilfield Technologies

Features:

- Precise to 0.0001 inches
- Easy to set up and use
- Portable - take it with you anywhere

Mud Pump Kit Includes:

- Microgage PRO Smart Display Unit
- Microgage Cylindrical Laser
- Microgage 2-Axis PRO Receiver
- Mud Alignment Receiver Mount
- Magnetic On/Off Mount
- Pinpoint Capture™ Software
- Computer USB Interface Cable
- Charger/Power Supply
- Hardshell Carrying Case
- Operation Manual
- 1 Year Warranty



About the Mud Pump Alignment Kit

Pinpoint's Mud Pump Alignment Kit has 3 main components, a laser transmitter, a digital receiver, and a display module. A highly collimated, low power laser beam is projected from the end of the laser housing and is aligned parallel to its mounting shank. The electronic receiver detects the laser beam and provides a digital readout showing the height and lateral position of the laser beam.

For more indepth application information, visit our website (pinpointlaser.com) and download our mudpump alignment white paper. You can also contact a Pinpoint Laser applications engineer at (978-532-8001)

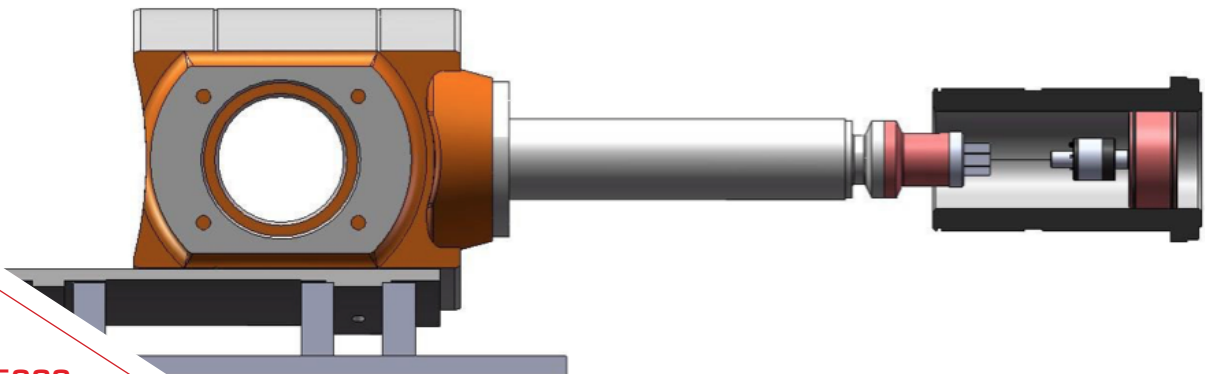

1-800-757-5383

www.pinpointlaser.com

info@pinpointlaser.com • Phone 978-532-8001 • 56 Pulaski Street • Peabody, MA 01960 • USA

Rev. 3/19